

# Photography



## Session 1

### Suggestions on How to Take Better Pictures

# My Name is Myron Sabes

My education was in the physical sciences,  
My career was in engineering

I have been taking photos for over 50 years  
Some good, some not so good,  
but some terrific

I am NOT a Professional Photographer  
Nor an Artist



**Some of My Photos  
Can Be Seen  
on My Web Site  
[MyronsPhotos.com](http://MyronsPhotos.com)**



# Taking Better Photos

## Session 1 Introduction



**Why we Take Photos**

## How We See, and How a Camera “Sees”

Our Eye has a Lens and  
A Light Sensitive Surface  
The Image is Interpreted by our  
Brain

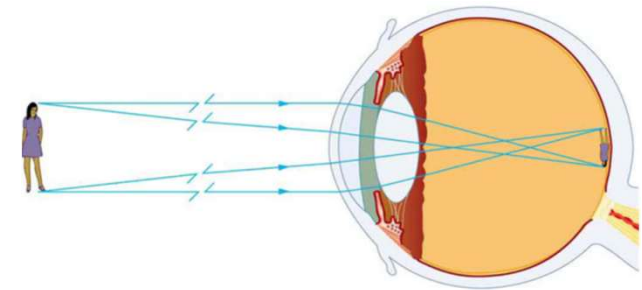

A Camera has a lens and  
A Light Sensitive Element  
Image is Captured by  
Film or Sensor

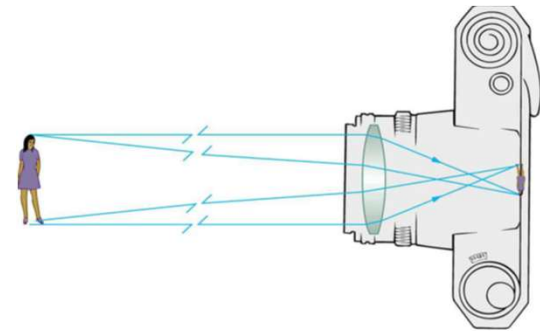

## a Brief History of Photography

The Daguerreotype was the first publicly available photographic process.

It was widely used in the 1840's and 1850's



Louis Daguerre



# Skipping Forward about 100 Years Photography Became Available to Families

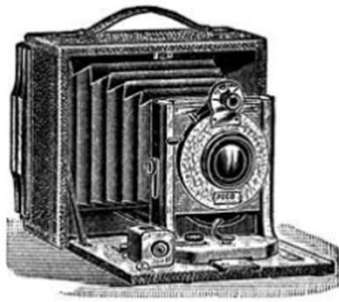

# Consumer Cameras and Film Evolved in the Late 60's Into the 90's



Yashica FR II 35mm SLR w/  
Yashica ML 50mm f/1.9 Lens



# Cameras Continued to Evolve And The Digital Camera Age Began



1995 Kodak introduced an affordable(?) digital camera for consumers the DC40

I bought and took photos with on  
Image size was 768 x 512 pixels

My Current “Best” camera is a  
Nikon D800. Purchased in 2012

Sensor size is the same as a 35mm slide  
image size of 7360 x 4912 pixels



# Now, a Quantum Leap to the Present The Cameras Most Used Today Are:



**iPhones**



**Androids**

**Cell Phones Made Photography Easy For Multitudes**

# Difference Between Good and Great Cameras?

Why are photographers willing to pay for an expensive camera?



**One Answer is Big Glass** (the lens) **and Big Sensors** (the camera's eye)

## With all this Cutting-Edge Technology Aren't All Photos Great?

Well, maybe not:

We may not be clear of outside influences  
Sun angle, Reflections, Shadows  
Background stuff

We may shoot without first thinking  
about what we want



# Even Professional Photographers Screw Up Once in a While



## *As the Price of Beef Soars, Restaurants Are in 'Code Red' Mode*

Midpriced steakhouses and fine-dining establishments are trying to figure out how to cover their rising costs without scaring away customers.

From an article in the New York Times: 12/10/2025

BUT: what is the central focus? The Beef!

The Red Bottle is an attention grabber seeming to be a tie-in from the paragraph header line.

Trying to show the Chef's technique in seasoning the meat but seasoning is obscured by the background red bottle

What about the butter-herb container occupying as much area as the beef?

**All This Technology Makes Taking Photos Easy  
But Does Not Ensure that  
our Photo Choices are Good**



**Good Photos are those that Mean Something  
These are not good examples**

## **First, We Need to Define What makes a Picture Good**



**If you don't know  
where you are going,  
you'll end up someplace else.  
Yogi Bera**

# A Good Picture Has Several Qualities

The picture Should Show Something of Interest and Serve a Purpose

The picture grabs and holds the Viewer's Attention

The picture makes good use of Light, Color, Contrast, Focus

A Pretty Good picture can be Made Better or maybe even Great

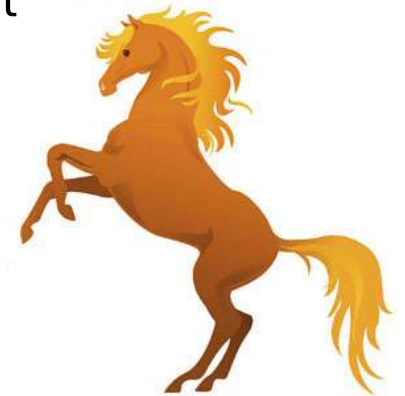

# Photographs Serve a Purpose

Unless you know the purpose, you cannot judge if something is Good

## Common Photo Purposes

Remembering

Celebrating

Documenting

Telling a Story

Capturing Nature

Artistic Expression



**Good Photos Often Overlap Several of These**

# Photographs Help Us Remember



# Good Photos Help Us Remember our Roots

Some of us are very lucky in that our Parents took and left Photos of our Family



It would be good for us to Leave a Legacy of Pictures to our Children

# **Lack of Good Photos Make it Harder to Remember our Roots**

Try not to let this happen to you and yours



Lost times and lost memories may not be recoverable

# Photos Help Us and Our Children Remember

Parents, Children, Family, Friends, and Acquaintances are in our lives, but time moves along.  
Memories of good times and good people are blessings



# Notes About Preserving Family Photos

## Cherish, Preserve, and Add To Your Family's Story in Photos

If you are Lucky Enough to Have Photos  
of Those No Longer With Us  
Remember How Valuable They Are  
Organize and Protect Them  
Label Each Photo with Name(s) and Date



Although not necessarily all of them: We do not need 52 photos of Grandpa's dog Fido.  
But we do want to keep enough to remember Grandpa and what made him special.

# Good Photos Help Us Remember Adventures



# When An Adventure Happens

## Try to Capture the Best Moments in Photos

Do Not Let your Camera get in the Way of Your Good Time,  
But Do Not be Bashful About Taking Photos

When your adventure is over and you are safely home,  
Try to Review your Photos while the Memories are Fresh  
Select the ones that best Show Your Memorable Moments

Later, Re-Review the Photos and Your Selection Choices

Resist the Temptation to Include Too Many Photos  
Too Many Photos Dilute the Memories

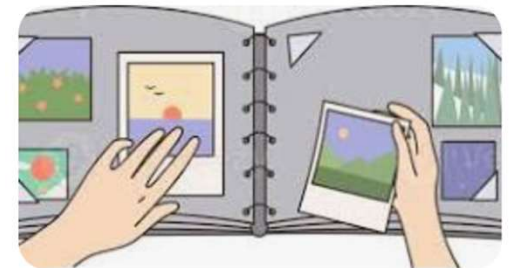

# Photographs Help Us Celebrate

Photos have become an important part of Celebrations For Most of Us.

As we gather to Celebrate Holidays or Milestones in Our Lives  
We want the future memories to keep and to cherish



Professional Photographers make a good living  
Photographing Weddings, etc.

People, Individually or and in Groups,  
Generally, Enjoy Being Included in the Festivities  
And Having their Photos Taken

## Good Photos Help Us Celebrate



Holidays and other Celebrations are terrific times to get Good Pictures of Family Members and Close Friends

# Photographs Help Us Document Our Lives



# Photos can Document our Accomplishments

Harley-Davidson Owners Group ( HOG ) used to sponsor an annual activity for members requiring submission of photos to prove you rode to Cities and Dealerships  
A point for each letter of the alphabet by proving you visited a city whose name begins with that letter



# Good Photos Help Us Document Circumstances

Pictures can determine the outcome of disputes.

After an Auto Accident, information can be exchanged by each party photographing the other driver's documents as well as the damages and surrounding area



If you need to file an insurance claim, having photos of the damage can be helpful.

Also, if you have jewelry, collectables, or other Valuable assets, a photographic inventory can document loss



## **Time For Questions**

**Remember, if You Have a Question  
And are a Little Shy to Ask,  
There May be Someone Else  
With the Same Question  
But who is Even More Shy**



# Photography



**Session 2**  
**Suggestions on**  
**How to Make Photos**  
**Become Pleasing Pictures**